

Quick Start Guide

STEP 1

Power Connections

The FX-200 is not shipped with a separate AC-DC Power Adaptor. If you have a Cisco ATA 186, Grandstream ATA 286, Sipura SPA-2000, Packet8 DTA 310, Motorola ATA, you should be able to use your ATA/Gateway's AC-DC Power Adaptor for both devices.

CAUTION: Be aware there are two versions of the FX-200. A black 5v model and a white 12v model. So be sure you have the right model for your ATA/Gateway. FYI: Cisco ATA 186, Grandstream ATA 286, Sipura SPA-2000 have a 5v AC-DC Power Adaptor so you need to use the black FX-200 with these units. Do not plug a 12v AC-DC Power Adaptor into the black FX-200 5v model. The Packet8 DTA 310 and the Motorola ATA use a 12v AC-DC Power Adaptor so you need to use the white 12v FX-200 with these.

Once you are sure you have the correct FX-200 model for your ATA/Gateway, simply plug the ATA/Gateway's AC-DC Power Adaptor into the **DC IN** jack of FX-200. Then connect the FX-200 **DC OUT** jack to your ATA/Gateway's DC in jack with the provided six inch Black & White Power Wire. Generally, **the white end plugs into the FX-200 and the black end plugs into the ATA/Gateway as shown below.**

CAUTION: If you mistakenly plug the ATA/Gateway's AC-DC Power Adaptor into the DC OUT jack of the FX-200 neither unit will function properly.

After powered on, both LEDs (S1 and S2) on the side of the FX-200 will be solid red. Also check to see if the power LED on the ATA/Gateway is also on.

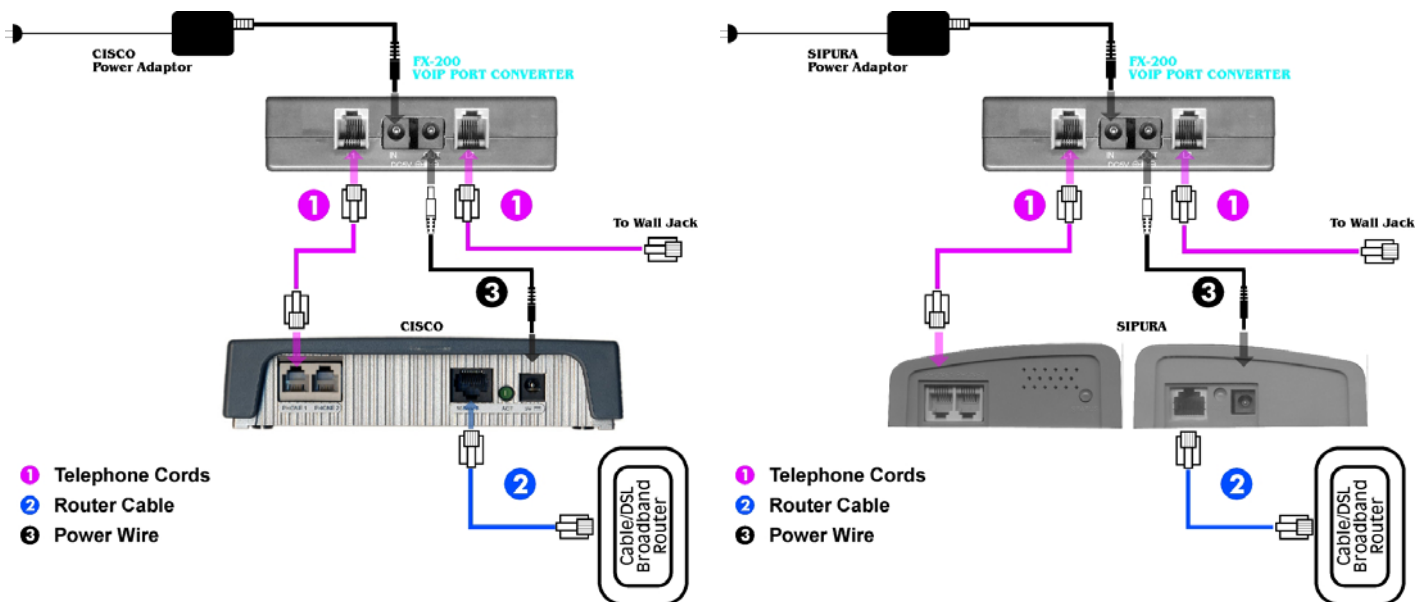

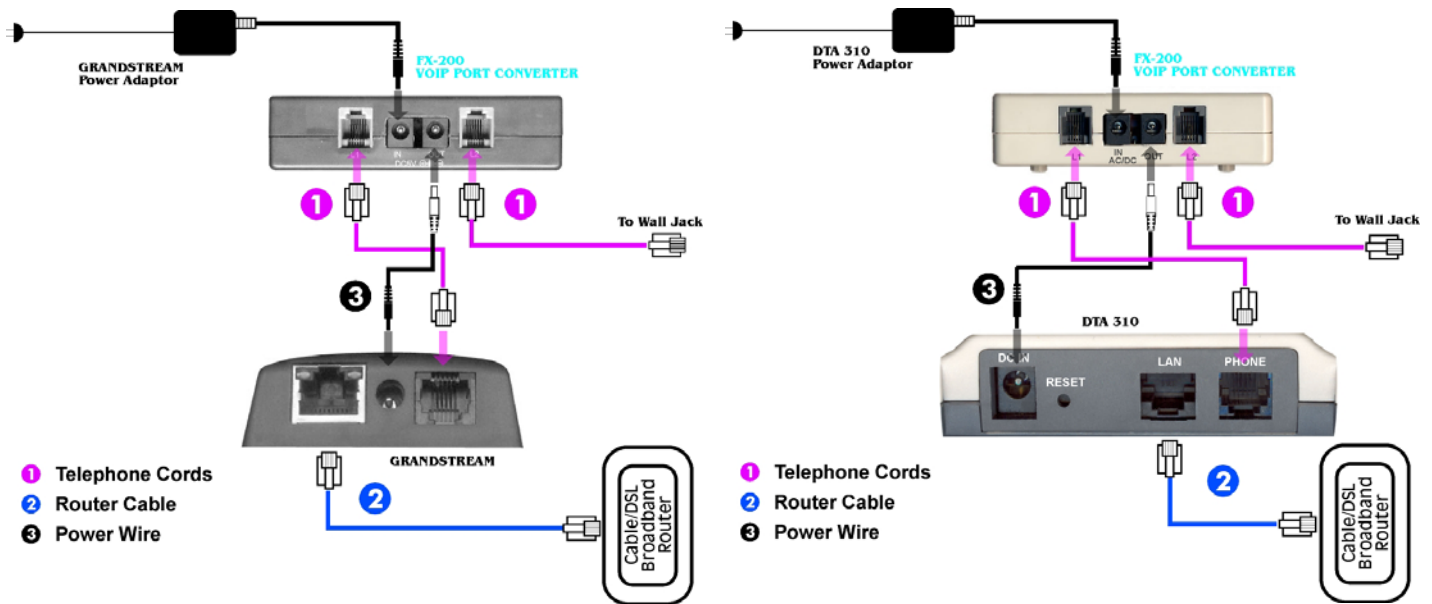

Basic Telephone Line Connections

In order to prepare to perform the busy tone tuning of the unit, you should next connect the telephone lines (included) as illustrated above. You can later connect the optional telephone T-Adaptors and your handsets after the unit is first successfully tuned to recognize your local Telco's busy tone.

Connections:

Connect Port L1 of the FX-200 to an active Phone Port on your ATA/Gateway.

Connect Port L2 of the FX-200 to an analog line, (your telephone line jack)

STEP 2

Manual Tuning for Busy Tone Detection

To ensure proper function with your local telephone network you should first adjust the busy tone detection function of the FX-200. To do so locate the **Variable Resistor Screw Dial** on the top of the unit and the **Test Button** on the bottom of the unit and the **S1 and S2 LEDs** on the side of the unit next to the TRANSIT IN switch.

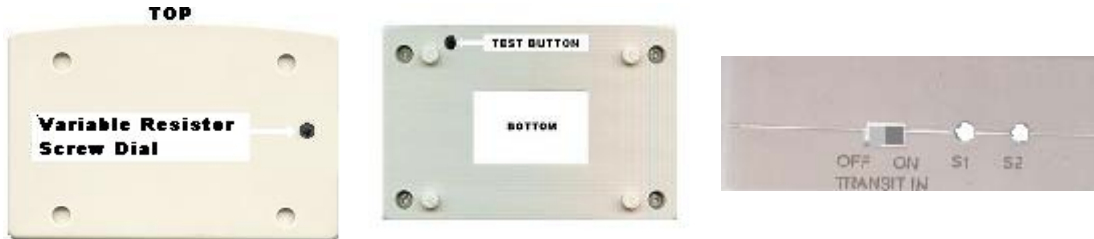

Tuning

Then, with the unit powered on and the lines connected as set out above, place a call to the telephone number of the line connected to L2, wait for the dial tone from the ATA/Gateways, then hang up the call and immediately push and release the Test Button. S1 will flash yellow. If S2 is also flashing yellow then the unit does not need to be tuned. Press the test button again to end the tuning procedure. (Note: All units are pre-tuned at the factory for US standard busy tone and most units will not need to be re-tuned) If S2 is not yellow **then slowly turn the Variable Resistor Screw Dial in both directions (with a small screw driver) until you find the position that causes LED S2 to flash yellow or stay solid yellow.** You have one minute to complete the tuning after you push the test button. When the tuning is completed both S1 and S2 will automatically revert to standby mode (default is solid red). Or alternatively, you may press the test button to manually end the tuning procedure.

Testing

After tuning, you should **test** to see if the tuning was successful by again placing a call to the telephone number of the line connected to L2, wait for the dial tone from the ATA/Gateway you are using, then hang up the call. If properly tuned, the FX-200 will disconnect from the telephone line and the ATA/Gateway within two minutes. If the FX-200 does not disconnect from the line and the ATA/Gateway within two minutes you will need to repeat the tuning procedure. If you experience disconnect delays at any time from either Transit In or Transit Out calls you may need to fine-tune the unit. To do so simply re-tune the unit while the unit is still attempting to disconnect from the Transit In or Transit Out call.

Note: If after tuning the unit as instructed above, you still encounter problems with the busy tone detection, contact customer service for assistance.

STEP 3

Basic Operation Guide

The FX-200's default settings for L1 and L2 are for Transit Out function with Two Stage Dialing for L1→L2 calls and Transit In function with Two Stage Dialing for L2→L1 calls.

Transit Out function with Two Stage Dialing

When the FX-200 receives a call to L1 from the ATA/Gateway the **S1 LED will flash red**, the FX-200 will auto answer the call, and redirect it to the telephone line connected to L2. Once the caller hears the dial tone from the telephone line connected to L2 they can make a local call over this telephone line. This is commonly referred to as **Transit Out function with Two Stage Dialing**. When the caller hangs up, the FX-200 will cut the connections, and the S1 LED will **return to solid red**. Callers can also make additional local calls (from one call to the ATA/Gateway) by pressing # # before hanging up. When the Caller presses # #, L2 will disconnect from the telephone line and then reconnect after 1 second and issue a new local dial tone to the caller. The caller can then make another local call.

Note: Not all networks support the passing of DTMF tones in a way that supports this function. If this is the case with your network you will be limited to using the FX-200 for Transit Out with Auto Call Forwarding.

Caution: the FX-200 will not block IDD, 900, or other toll calls over your telephone line. To do so, you will need to contact your local telephone line company to enable toll call blocking functions where desired/available.

Transit In function with Two Stage Dialing

When the FX-200 receives a call to L2 from the telephone line FX-200's response will depend on the setting (On/OFF) of the **Transit In** switch on the side of the FX-200 next to the S1 and S2 LEDs.

Note: The Transit In switch setting may be changed while the power is on, a reboot is not required in order for the new setting to take effect.

When the Transit In switch is set to OFF a call to the telephone line connected to L2 will not activate the FX-200 and the call may be answered by any other phone/fax connected to the telephone line via a telephone line T-Adaptor. In this mode incoming calls to your home or office line will flow through as normal.

When the Transit In switch is set to ON a call to the telephone line connected to L2 will activate the FX-200. **S2 LED will flash red**, the FX-200 will auto answer the call and redirect it to the ATA/Gateway Phone Port connected to L1. The caller will receive dial tone from the ATA/Gateway and will be able to remotely operate the ATA/Gateway in the same way they would if connected directly with a normal handset. Thus, once the caller hears the dial tone from the ATA/Gateway they can make a call through the ATA/Gateway. This is commonly referred to as **Transit Out function with Two Stage Dialing**. When the caller hangs up, the FX-200 will cut the connections, and the S1 will **return to solid red**. The Caller can also make additional calls through the ATA/Gateway by pressing # # before hanging up. When the Caller presses # # L1 will disconnect from the ATA/Gateway and then reconnect to the ATA/Gateway after 1 second and issue the caller a new dial tone from the ATA/Gateway. Callers can then make another call through the ATA/Gateway. In this mode you can access the ATA/Gateway and your VOIP service from outside your home or office. Simply call the number of the telephone line connected to the FX-200 from an outside line or from your cell phone.

Your FX-200 is now ready for basic operation!